

The Effects of Dzyaloshinsky-Moriya Interaction in the Orthogonal Dimer Heisenberg Model for $\text{SrCu}_2(\text{BO}_3)_2$

Shin MIYAHARA¹ and Frédéric MILA²

¹*Department of Physics and Mathematics, Aoyama Gakuin University, Sagamihara 229-8558, Japan*

²*Ecole Polytechnique Fédérale de Lausanne, Lausanne, CH-1015, Switzerland*

The new two-dimensional spin-gap system $\text{SrCu}_2(\text{BO}_3)_2$ shows unique physical properties because of its low-dimensionality character and of strong quantum fluctuations due to frustration. The magnetic properties of the material, e.g. dimer singlet ground state, an almost localized triplet and magnetization plateaus, are well described by a spin-1/2 antiferromagnetic Heisenberg model on the orthogonal dimer lattice. However, in the presence of an external magnetic field, unusual magnetic properties, which cannot be explained by the Heisenberg model alone, have been observed in several experiments: (1) a field induced staggered moment, (2) the persistence of an excitation gap at around the critical field, and (3) a finite magnetization below the critical field. We include intra- and inter-dimer Dzyaloshinsky-Moriya interactions and the staggered gyromagnetic tensors in the orthogonal dimer Heisenberg model, and show that these unusual behaviors with the external field in the z direction can be well described with physically reasonable values of the parameters.

§1. Introduction

In 1981, Shastry and Sutherland proposed an exact ground state for a spin-1/2 Heisenberg model on an artificial two-dimensional lattice, the so-called Shastry-Sutherland model.¹⁾ It seemed difficult to find a material which is a realization of the Shastry-Sutherland model, but such a structure is actually realized as a topologically equivalent orthogonal dimer structure in a new two-dimensional material $\text{SrCu}_2(\text{BO}_3)_2$.^{2),3)} After its discovery, much attention has been paid to $\text{SrCu}_2(\text{BO}_3)_2$ and many experimental and theoretical investigations have been performed.⁴⁾ These days it is confirmed that an exact dimer singlet ground state proposed by Shastry and Sutherland is realized in this material. Due to strong quantum fluctuations strengthened by the special geometrical frustration of the lattice, the material shows unique physical properties, e.g. spin gap and magnetization plateaus. Most of the magnetic properties in this material are well explained by the spin-1/2 Heisenberg model on an orthogonal dimer lattice.

Recently, nuclear magnetic resonance (NMR) measurements have been done in external magnetic fields. The results at low temperatures indicate several novel phenomena: a symmetry breaking ground state at the 1/8-plateau,⁵⁾ a field induced staggered moment, a finite magnetization below the critical field, and the persistence of an excitation gap around the critical field.⁶⁾ Although the breaking of the translational symmetry can be explained by the Heisenberg model,⁷⁾ perturbative inclusion of the effects of Dzyaloshinsky-Moriya interactions and the staggered gyromagnetic tensors is necessary to explain the latter three features.⁶⁾

In this paper, we discuss the features of the field induced magnetic properties in

a field along the z -direction using perturbation theory not only for Dzyaloshinsky-Moriya interactions on dimer bonds and staggered gyromagnetic tensors, as done in Ref. 8), but also Dzyaloshinsky-Moriya interactions between dimers.⁹⁾ First, we discuss the spin moments for the ground state. Staggered and uniform moments are induced by the external field, but the former is much larger than the latter, which is consistent with the experimental results. Then, the excitation gap around the critical field H_c , where the spin gap should vanish if Dzyaloshinsky-Moriya interactions were not present, is discussed. The behavior of the excitation gap strongly depends on the sign of the inter-dimer Dzyaloshinsky-Moriya interactions.

§2. The orthogonal dimer model for $\text{SrCu}_2(\text{BO}_3)_2$

The spin Hamiltonian for $\text{SrCu}_2(\text{BO}_3)_2$ (see Fig. 1) is written as

$$\begin{aligned}
 H = & J \sum_{\text{n.n.}} \mathbf{s}_i \cdot \mathbf{s}_j + J' \sum_{\text{n.n.n.}} \mathbf{s}_i \cdot \mathbf{s}_j \\
 & + D_y \sum_{\text{A-dimer}} (s_1^z s_2^x - s_1^x s_2^z) + D_x \sum_{\text{B-dimer}} (s_3^y s_4^z - s_3^z s_4^y) \\
 & + D'_z \sum_{\text{n.n.n.}} (s_i^x s_j^y - s_i^y s_j^x) \\
 & - \sum_{\text{unitcell}} ((\hat{g}_1 \mathbf{H}) \cdot \mathbf{s}_1 + (\hat{g}_2 \mathbf{H}) \cdot \mathbf{s}_2 + (\hat{g}_3 \mathbf{H}) \cdot \mathbf{s}_3 + (\hat{g}_4 \mathbf{H}) \cdot \mathbf{s}_4). \quad (2.1)
 \end{aligned}$$

The first two terms correspond to the Shastry-Sutherland Heisenberg model. The 3rd and 4th terms represent Dzyaloshinsky-Moriya interactions on nearest-neighbor bonds. Since there is a buckling in xy plane,¹⁰⁾ the center of the J bonds is not an inversion symmetry point and the components of the Dzyaloshinsky-Moriya interaction shown in Fig. 1 can exist.¹¹⁾ Using symmetry operations, the relation $D_x = -D_y$ is obtained. The 5th term represents the Dzyaloshinsky-Moriya interactions on the next-nearest-neighbor bonds.⁹⁾ The direction of Dzyaloshinsky-Moriya vectors is indicated in Fig. 1, where we fix the direction from i to j for a pair i, j as shown in Fig. 1. From the symmetry of the lattice, in-plane components of Dzyaloshinsky-Moriya vectors can also exist. However, we neglect them with the hope that they are smaller than the z component and hardly affect the magnetic properties. The effects of the external field are described by the 6th term. In the model, there are two inequivalent dimers, horizontal (A-dimer) and perpendicular (B-dimer) ones. Thus the unit cell contains four inequivalent spin sites i.e. four inequivalent gyromagnetic tensors. The gyromagnetic tensors on each site are written as

$$\hat{g}_1 = \begin{pmatrix} g_x & 0 & g_s \\ 0 & g_y & 0 \\ g_s & 0 & g_z \end{pmatrix}, \quad \hat{g}_2 = \begin{pmatrix} g_x & 0 & -g_s \\ 0 & g_y & 0 \\ -g_s & 0 & g_z \end{pmatrix}. \quad (2.2)$$

$$\hat{g}_3 = \begin{pmatrix} g_y & 0 & 0 \\ 0 & g_x & g_s \\ 0 & g_s & g_z \end{pmatrix}, \quad \hat{g}_4 = \begin{pmatrix} g_y & 0 & 0 \\ 0 & g_x & -g_s \\ 0 & -g_s & g_z \end{pmatrix}. \quad (2.3)$$

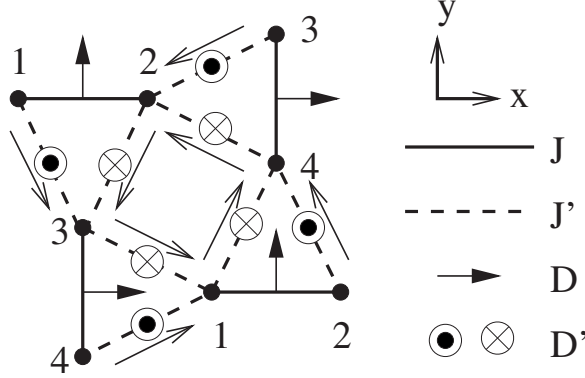

Fig. 1. The orthogonal dimer model for $\text{SrCu}_2(\text{BO}_3)_2$. The unit cell contains four inequivalent spin sites. The direction of the possible Dzyaloshinsky-Moriya interactions is also indicated.

From electron spin resonance (ESR) experiments, the diagonal terms were estimated to be $g_x = g_y = 2.05$ and $g_z = 2.28$.¹²⁾ The off-diagonal elements g_s are staggered, i.e. they are opposite on sites 1 and 2, 3 and 4.

§3. Field induced spin moment

In the absence of Dzyaloshinsky-Moriya interactions and external field, the ground state of the Hamiltonian (2.1) is written as the product of singlet states on dimer bonds:

$$|s\rangle = \prod_i |s\rangle_i = \prod_i \frac{1}{\sqrt{2}} (|\uparrow\downarrow\rangle_i - |\downarrow\uparrow\rangle_i), \quad (3.1)$$

where i denotes nearest-neighbor bonds. To clarify the effects of Dzyaloshinsky-Moriya interactions and staggered gyromagnetic tensors, we performed a perturbation calculation for the dimer singlet ground state in the limit $D_y/J, D'_z/J, H/J \ll J'/J \ll 1$. Since most of the magnetic properties can be well described by the Heisenberg model, it is natural to assume that D_y, D'_z are much smaller than J . The perturbation of D_y, D'_z and $g_s H_z$ mixes the singlet ground state and the triplet excited states since the $SU(2)$ symmetry is broken. Up to the fifth order of J'/J , the triplet excitation is localized and, therefore, the effects of J'/J are taken into account easily, by replacing an excitation energy from singlet to triplet state with a corrected value Δ_s . The spin gap Δ_s of the fifth order perturbation is written as¹³⁾

$$\frac{\Delta_s}{J} = 1 - \left(\frac{J'}{J}\right)^2 - \frac{1}{2} \left(\frac{J'}{J}\right)^3 - \frac{1}{8} \left(\frac{J'}{J}\right)^4 + \frac{5}{32} \left(\frac{J'}{J}\right)^5. \quad (3.2)$$

In the presence of an external field along the z -direction $\mathbf{H} = (0, 0, H_z)$, the expectation values $\langle S_i^x \rangle$, $\langle S_i^y \rangle$ and $\langle S_i^z \rangle$ are calculated up to the third order in $D_y/J, D'_z/J$ and H_z/J . The staggered moments are given by

$$\langle S_1^x \rangle = -\langle S_2^x \rangle = \langle S_3^y \rangle = -\langle S_4^y \rangle = \frac{D_y g_z H_z}{2\Delta_s} + \frac{g_s H_z}{2\Delta_s}, \quad (3.3)$$

and the uniform magnetization is written as

$$\langle S_1^z \rangle = \langle S_2^z \rangle = \langle S_3^z \rangle = \langle S_4^z \rangle = \frac{(D_y + 2g_s H_z)^2 g_z H_z}{4\Delta_s^3}. \quad (3.4)$$

The other components $\langle S_1^y \rangle$, $\langle S_2^y \rangle$, $\langle S_3^x \rangle$ and $\langle S_4^x \rangle$ vanish. So, a uniform magnetization appears even below the critical field H_c . However, it is tiny in small field, since it is proportional to D_y^2 and g_s^2 . On the other hand, the staggered magnetizations are proportional to D_y and g_s . Thus, the staggered moments are much larger than the uniform magnetization. Note that the effects of the Dzyaloshinsky-Moriya interaction D'_z are negligible.

Such a field induced staggered magnetization has been observed in SrCu₂(BO₃)₂ in ¹¹B NMR experiments in a field small compared to the spin gap Δ_s ,⁶⁾ which is qualitatively consistent with the results of the perturbation calculation. In the magnetization curve, a uniform magnetization has been observed in fields $H \gtrsim 2\Delta_s/3$,¹⁴⁾ in agreement with the fact that the uniform magnetization is too small as indicated in Eq. (3.4) in small field. In fact, the field dependence of the uniform and staggered magnetization can be quantitatively well explained by a finite size calculation using the parameters $D_y/J = 0.034$ and $g_s = -0.023$ as shown in Ref. 6).

§4. Persistence of gap at around critical field

Let us consider the behavior of the excitation gap in external fields such that $0 < (\Delta - H_z)/J \ll 1$. For such fields, we can restrict ourselves to the ground state $|s\rangle$ and the lowest excited state. In an external field along the z direction, the lowest excited state is a state where one of the singlets is promoted to the $|t_1\rangle$ triplet on a dimer bond:

$$|e_1(i)\rangle = |t_1\rangle_i \prod_{j \neq i} |s\rangle_j. \quad (4.1)$$

Using a Fourier transformation of the excited states (4.1), the lowest excited states are written as $|e_1(\mathbf{q})\rangle_\alpha$ ($\alpha = A$ or B). In the state $|e_1(\mathbf{q})\rangle_A$ ($|e_1(\mathbf{q})\rangle_B$), the triplet state $|t_1\rangle_i$ is located on A -dimers (B -dimers). Since the bandwidth of the triplet excitation is proportional to $(J'/J)^6$, the lowest excited states are almost degenerate. Such a degeneracy can be lifted by the introduction of inter-dimer Dzyaloshinsky-Moriya interactions D' and the lowest state and its energy are described by

$$|e_1(0)\rangle_+ = \frac{1}{\sqrt{2}} (|e_1(0)\rangle_A + i|e_1(0)\rangle_B) \quad J - 2D' \quad (D' > 0), \quad (4.2)$$

$$|e_1(0)\rangle_- = \frac{1}{\sqrt{2}} (|e_1(0)\rangle_A - i|e_1(0)\rangle_B) \quad J + 2D' \quad (D' < 0), \quad (4.3)$$

where the band width of the lowest excited states is proportional to D' .⁹⁾ Note that $|D'|/J = 0.02$ was required to explain the splitting of the lowest triplet branch observed in neutron scattering experiments.⁹⁾ Although the introduction of intradimer Dzyaloshinsky-Moriya interactions D and staggered g -tensors also split the lowest excited states, the bandwidth is proportional to D^2 and g_s^2 , which is negligible

compared with that produced by the inter-dimer Dzyaloshinsky-Moriya interactions D' . Taking into account the two lowest energy states $|s\rangle$ and $|e_1(0)\rangle_+$ ($|e_1(0)\rangle_-$), the excitation gap Δ to 1st order perturbation in D/J , D'/J and g_s is given by:

$$\Delta = \begin{cases} \Delta_s - 2D'_z - g_z H_z & \frac{D'_z}{D_y} > 0, \\ \sqrt{(\Delta_s + 2D'_z - g_z H_z)^2 + (D_y + g_s H_z)^2} & \frac{D'_z}{D_y} < 0. \end{cases} \quad (4.4)$$

We observe that the field dependence of the excitation gap around critical field H_c strongly depends on the sign of D'_z/D_y . For $D'_z/D_y > 0$, the gap vanishes at $g_z H = \Delta_s - 2D'$. On the other hand, the gap persists around the critical fields in the case $D'_z/D_y < 0$. Such a difference is well explained by considering the matrix elements caused by the Dzyaloshinsky-Moriya and staggered g -tensor terms H_{DM} :

$$+\langle e_1 | H_{DM} | s \rangle = 0, \quad (4.5)$$

$$-\langle e_1 | H_{DM} | s \rangle = D_y/2. \quad (4.6)$$

It is obvious that, when the lowest excitation mode is $|e_1\rangle_+$, there is a level crossing around the critical field. However, for the lowest excited state $|e_1\rangle_-$, an anticrossing occurs and the excitation gap can be finite even around the critical field. So, the behavior around the critical fields strongly depends on the sign of D'_z/D_y . If $D'_z/D_y < 0$, a gap opens, while if $D'_z/D_y > 0$, there is no gap. In ESR¹⁵⁾ and NMR⁶⁾ experiments, the persistence of the excitation gap around the critical field has been observed, which indicates that the condition $D'_z/D_y < 0$ is satisfied in $\text{SrCu}_2(\text{BO}_3)_2$. Around the critical field $g_z H_c = \Delta_s + 2D'$, the magnitude of the gap is estimated to be about 3 K, using the parameter values $D/J = 0.034$ K, $|D'|/J = 0.02$ K, $J = 85$ K, $\Delta_s = 35$ K, and $g_s = -0.023$.^{4),6),9)} The result is consistent with the experimental results, where the gap is estimated as $\Delta \sim 5$ K.^{6),15)} As a confirmation, first-principle calculations for the Dzyaloshinsky-Moriya interactions would be highly desired.

§5. Conclusion

In summary, the exotic field induced behaviors (field induced staggered moment, persistence of the excitation gap, the finite magnetization below the critical field) can be well explained including the effects of the Dzyaloshinsky-Moriya interactions and staggered components of g -tensor in a field H_z . Although we have investigated the case where the external field is applied in the z -direction, it is expected that unusual field induced behaviors for an arbitrary direction of the fields can be accounted for along the same lines.

In this paper, we have limited our analysis to the case $H \lesssim H_c$. However, Dzyaloshinsky-Moriya interactions and staggered components of g -tensor may play an important role for the magnetization even in higher fields, especially around the plateaus. For example, the slope of the magnetization is completely different below or above the 1/4-plateau. Such a difference may originate from the level crossing or anticrossing based on the ground state symmetry induced by the Dzyaloshinsky-Moriya interactions, like the gap behaviors at the critical field. In addition to that,

just above the critical field the effects of the two-triplet bound state^{16)–18)} should be taken into account, too.

Acknowledgements

We would like to express our sincere thanks to M. Takigawa, K. Kodama, M. Horvatić, C. Berthier and H. Kageyama for continuous discussions on experimental results. We thank K. Ueda and N. Furukawa for many helpful discussions. This work is supported by a Grant-in-Aid from the Ministry of Education, Culture, Sports, Science and Technology of Japan.

References

- 1) B. S. Shastry and B. Sutherland, *Physica B* **108** (1981), 1069.
- 2) H. Kageyama et al., *Phys. Rev. Lett.* **82** (1999), 3168.
- 3) S. Miyahara and K. Ueda, *Phys. Rev. Lett.* **82** (1999), 3701.
- 4) S. Miyahara and K. Ueda, *J. of Phys.: Cond. Mat.* **15** (2003), R327.
- 5) K. Kodama et al., *Science* **298** (2002), 395.
- 6) K. Kodama et al., *J. of Phys.: Cond. Mat.* **17** (2005), L61.
- 7) S. Miyahara, F. Becca and F. Mila, *Phys. Rev. B* **68** (2003), 024401.
- 8) S. Miyahara et al., *J. of Phys.: Cond. Mat.* **16** (2004), S911.
- 9) O. Cépas et al., *Phys. Rev. Lett.* **87** (2001), 167205.
- 10) K. Sparta, *Eur. Phys. J. B* **19** (2001), 507.
- 11) T. Moriya, *Phys. Rev.* **117** (1960), 635.
- 12) H. Nojiri et al., *Physica B* **294-295** (2001), 14.
- 13) Z. Weihong, J. Oitmaa and C. J. Hamer, *Phys. Rev. B* **65** (1999), 6608.
- 14) K. Onizuka et al., *J. Phys. Soc. Jpn.* **69** (2000), 1016.
- 15) H. Nojiri et al., *J. Phys. Soc. Jpn.* **68** (1999), 2906.
- 16) Y. Fukumoto, *J. Phys. Soc. Jpn.* **69** (2000), 2755.
- 17) C. Knetter, A. Bühler, E. Müller-Hartmann and G. S. Uhrig, *Phys. Rev. Lett.* **85** (2000), 3958.
- 18) K. Totsuka, S. Miyahara and K. Ueda, *Phys. Rev. Lett.* **86** (2001), 520.